

Icematic®

in cubetti

N90L

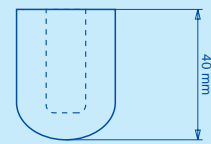
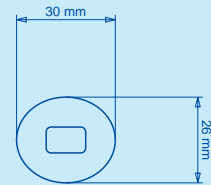

Ice cubers



Ice produced for 24 hours up to

kg. 90

ICE PRODUCTION

Condensing unit cooling **air** or water: consumption n. 37 litres per hour*

WATER COOLED

Absorbed power **W 670**

Water temperature

Refrigerant **R 134a**

Water inlet connection **3/4" Gas**

Water output connection **mm. Ø 20**

Single phase input **220V-240V - 50 Hz**

Ambient temperature

°C	32°	21°	15°	10°	
10°	77	84	87	90	kg
21°	71	77	81	84	kg
32°	70	76	79	82	kg
38°	66	71	74	76	kg

Ice prod. per 24 h

Extra voltages: **on request**

AIR COOLED

Storage bin capacity **kg. 42**

Water temperature

External structure **standard (1)**

Ambient temperature

°C	32°	21°	15°	10°	
10°	75	83	87	90	kg
21°	70	76	80	82	kg
32°	62	67	70	72	kg
38°	50	54	56	58	kg

Ice prod. per 24 h

Net weight **kg. 72**

(*) with water temperature 15 °C

Panels in skinplate blue coloured

Dimensions

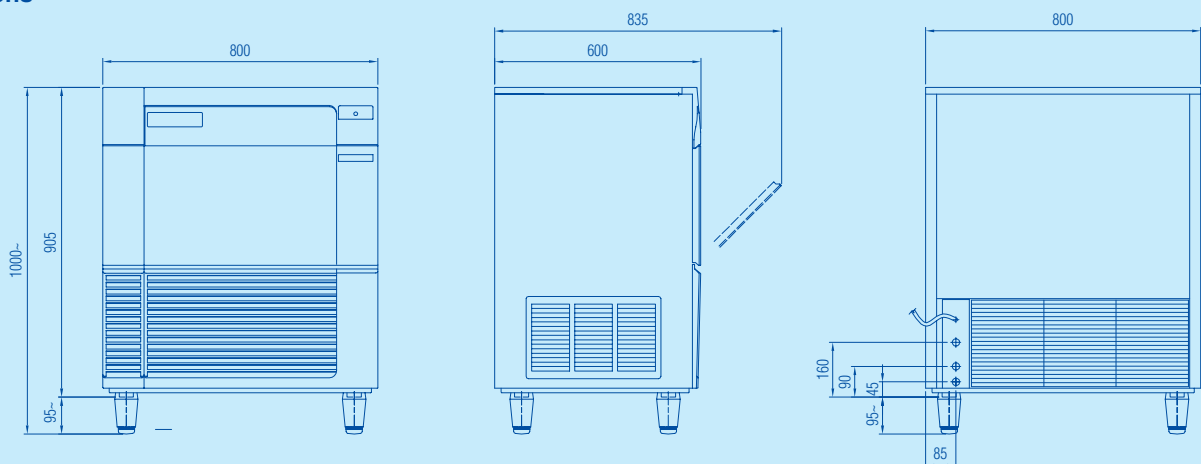

Castel MAC SpA



Aishwarya Consolidates Pvt. Ltd.,
 #19, Frist Floor, 10th 'B' Main, 27th Cross,
 Third Block Jayanagar, BANGALORE – 560 011, INDIA
 Tel: +91-80-2664 1200/1/2 Fax: +91-80-2664 1204
 E-mail : aishtek@vsnl.com www.aishwaryaconsolidates.com